

● 115V

★ 230V

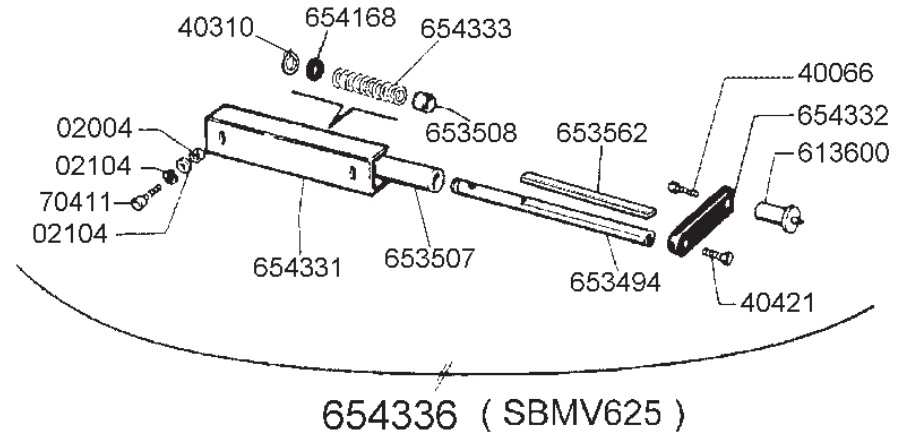

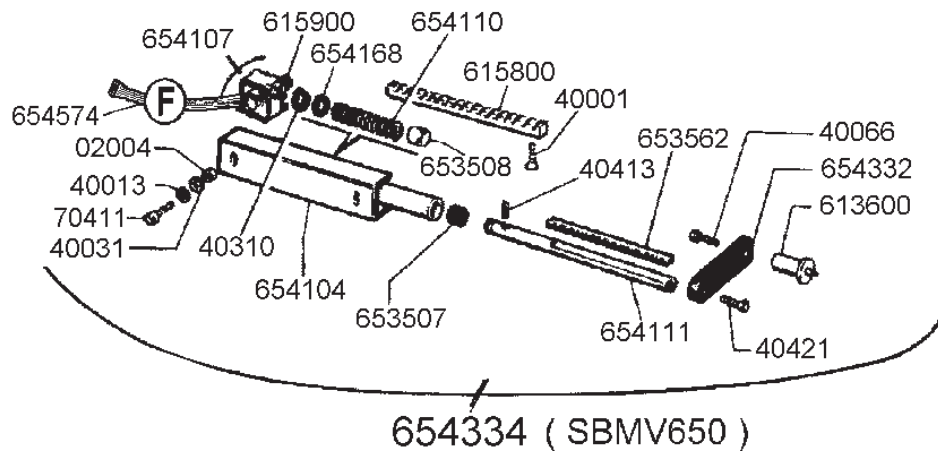

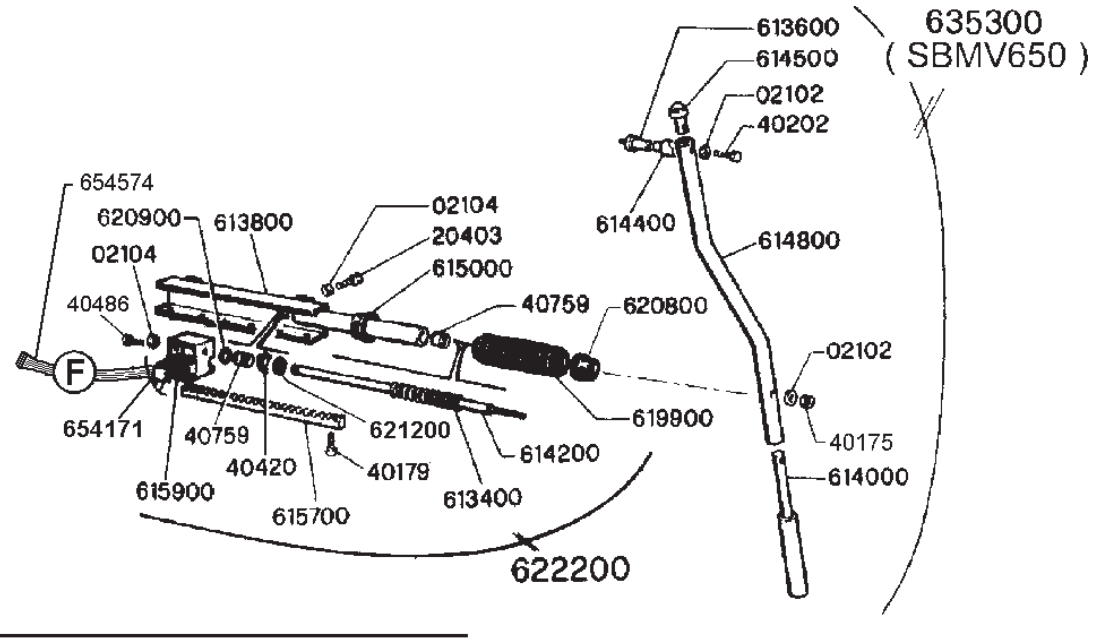
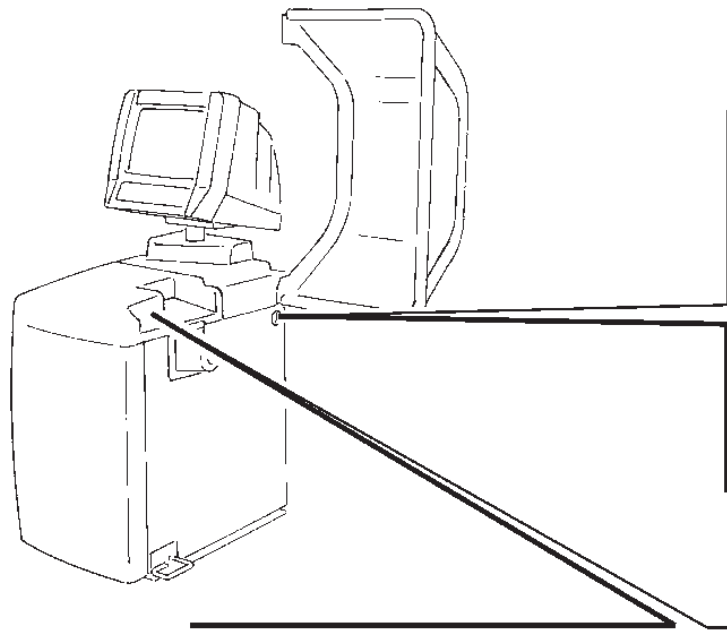
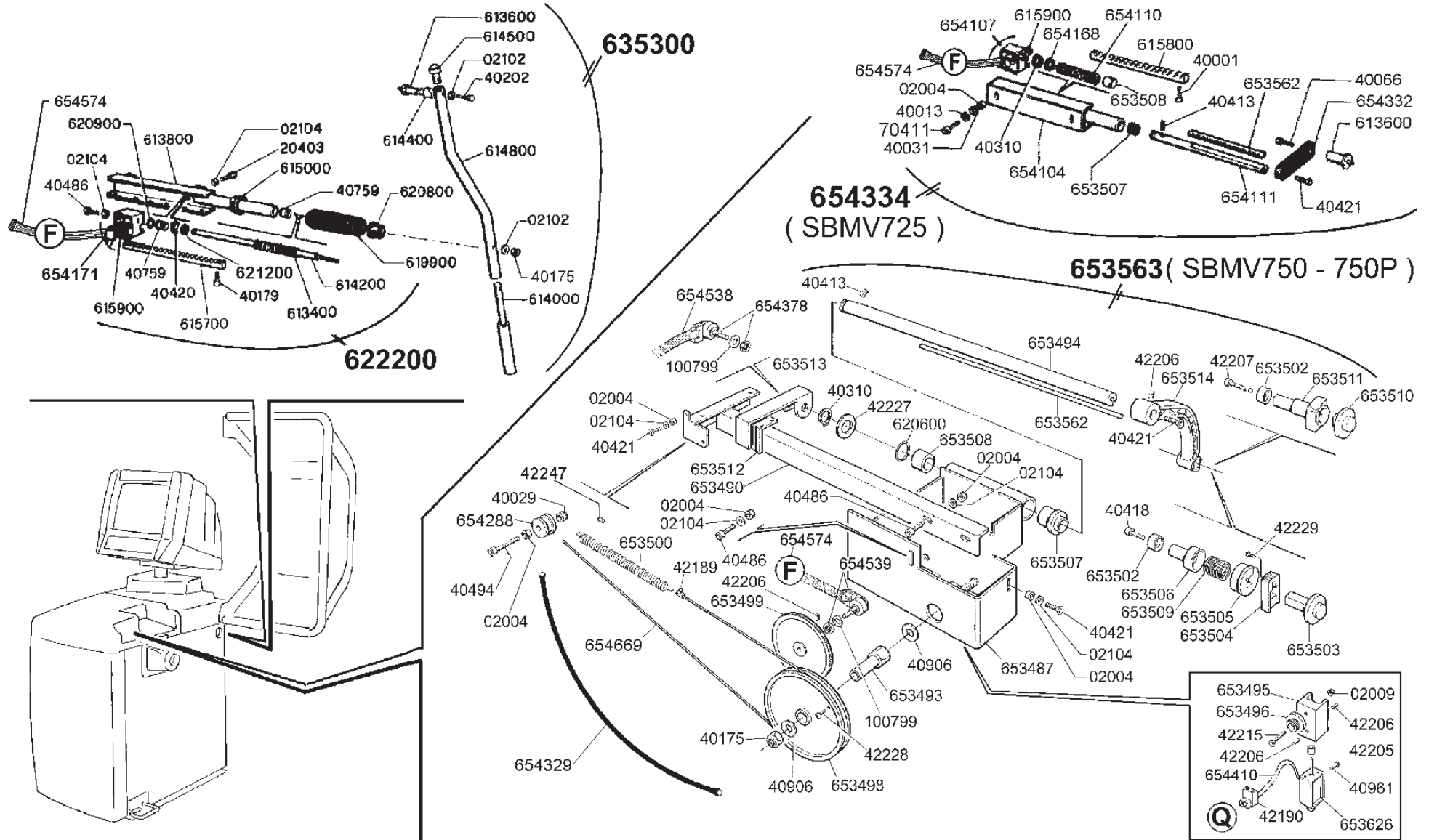
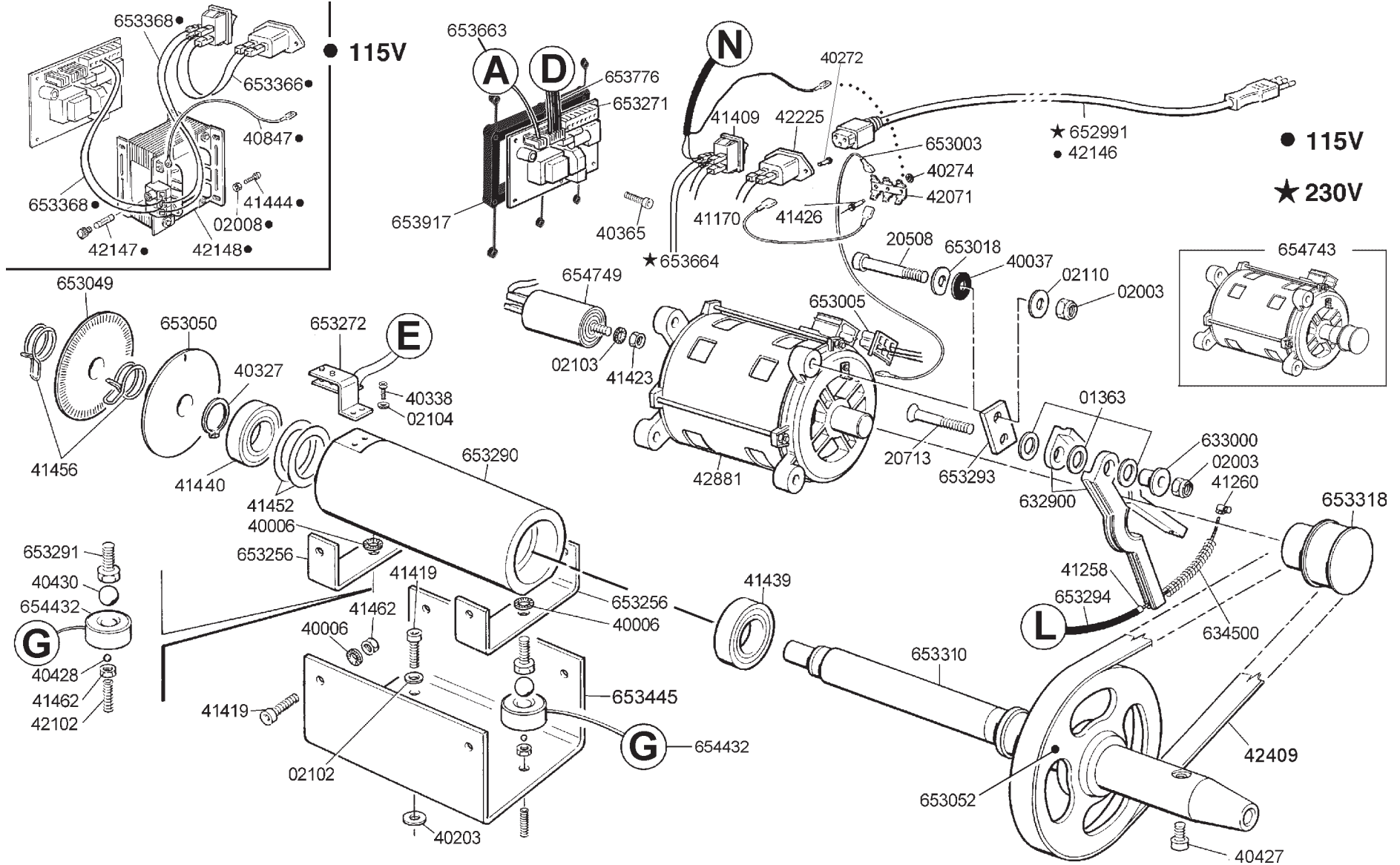

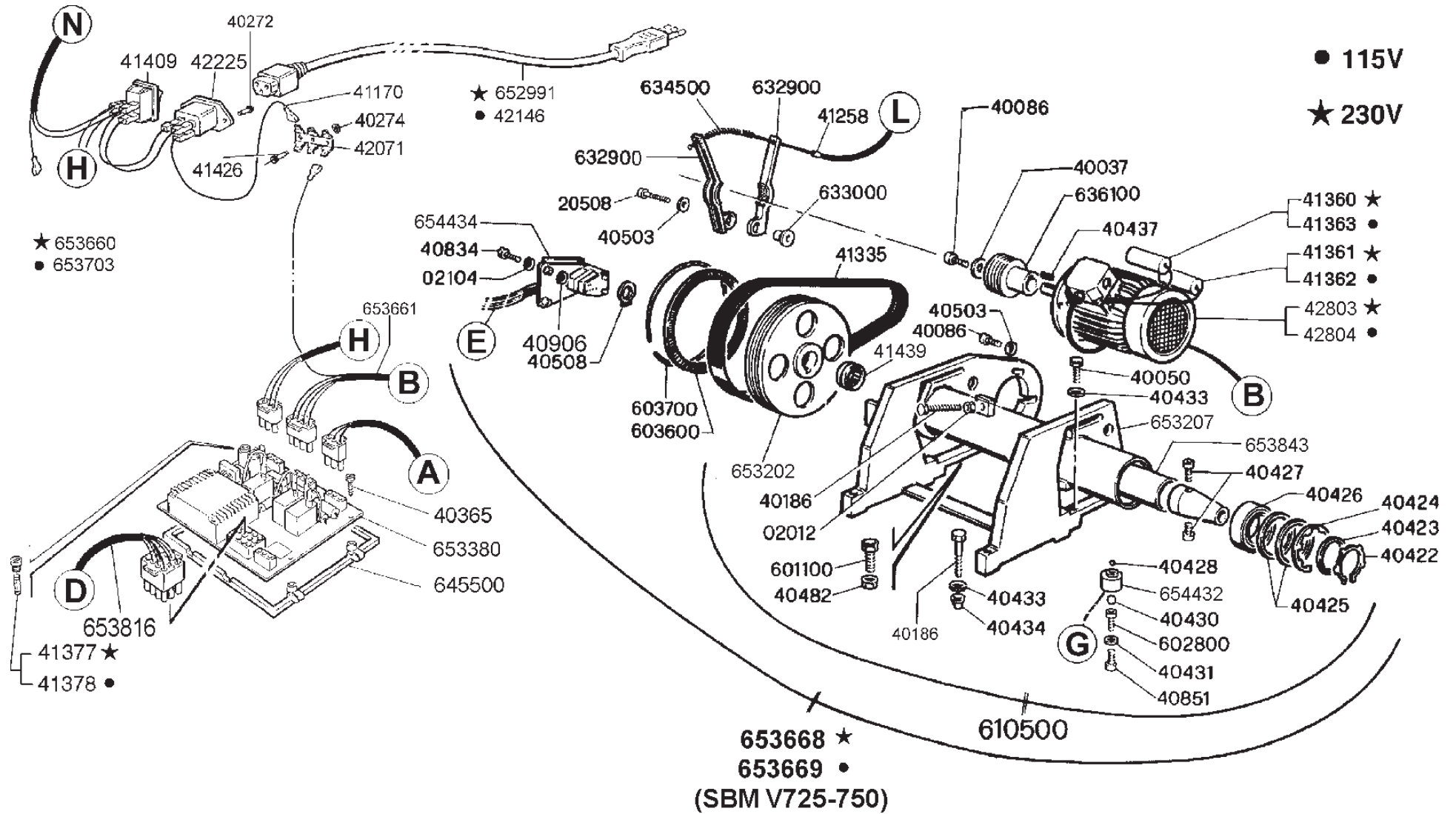

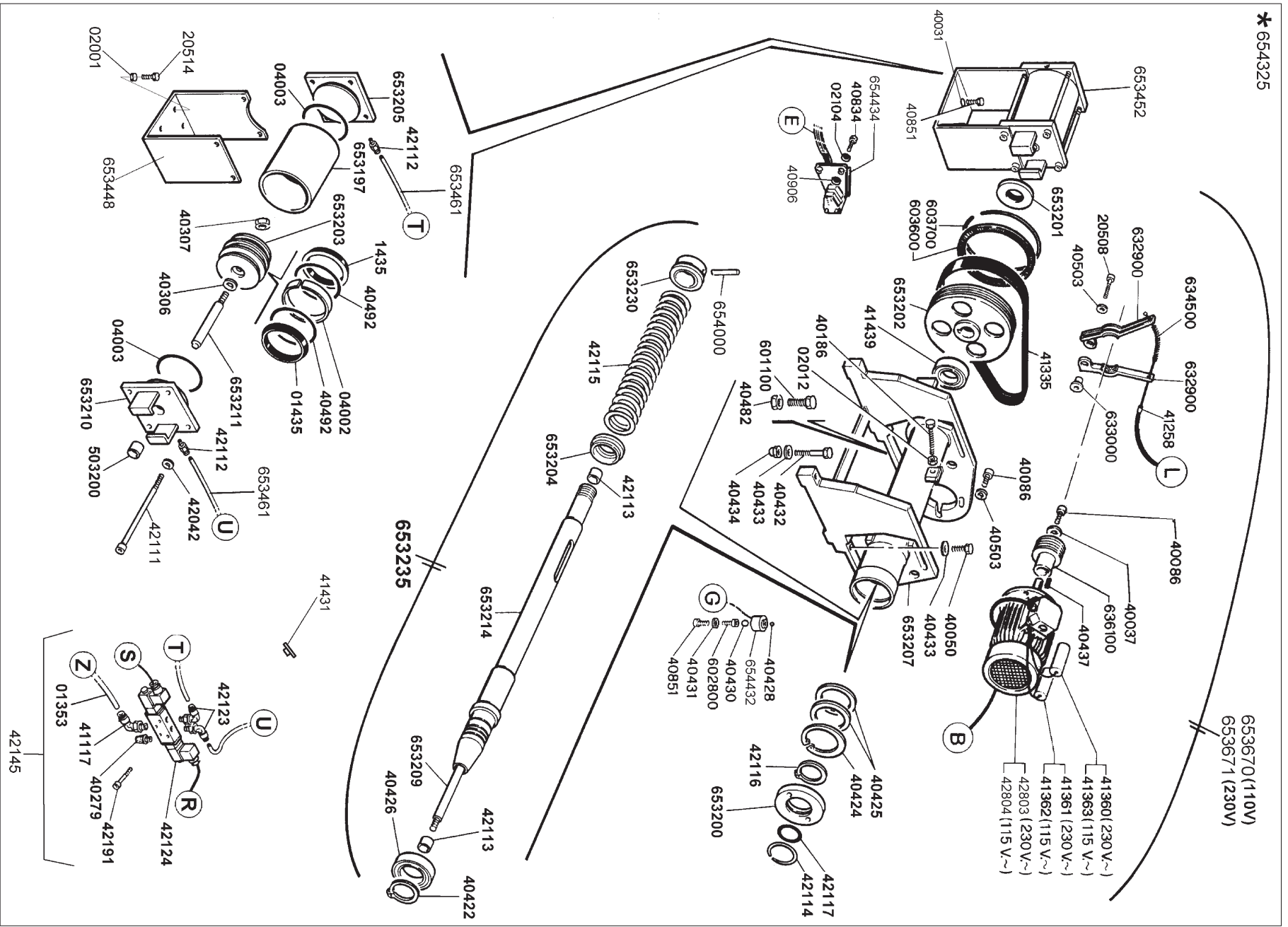

STANDARD

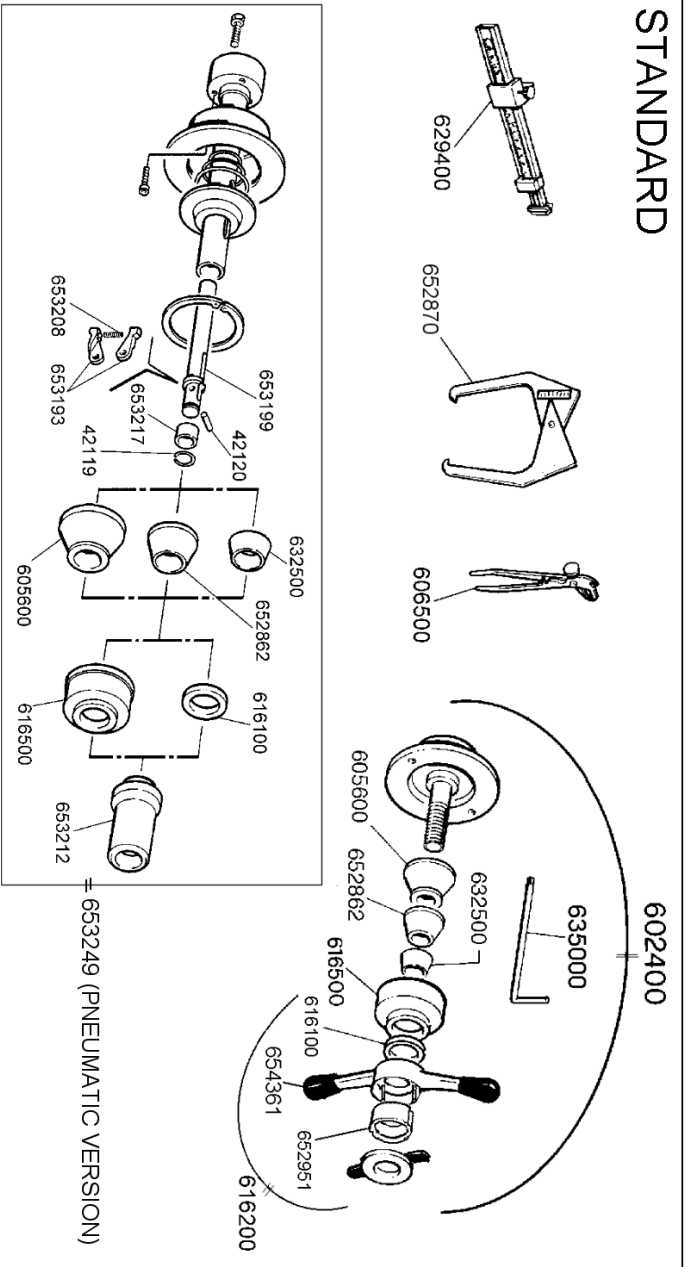

OPTIONAL

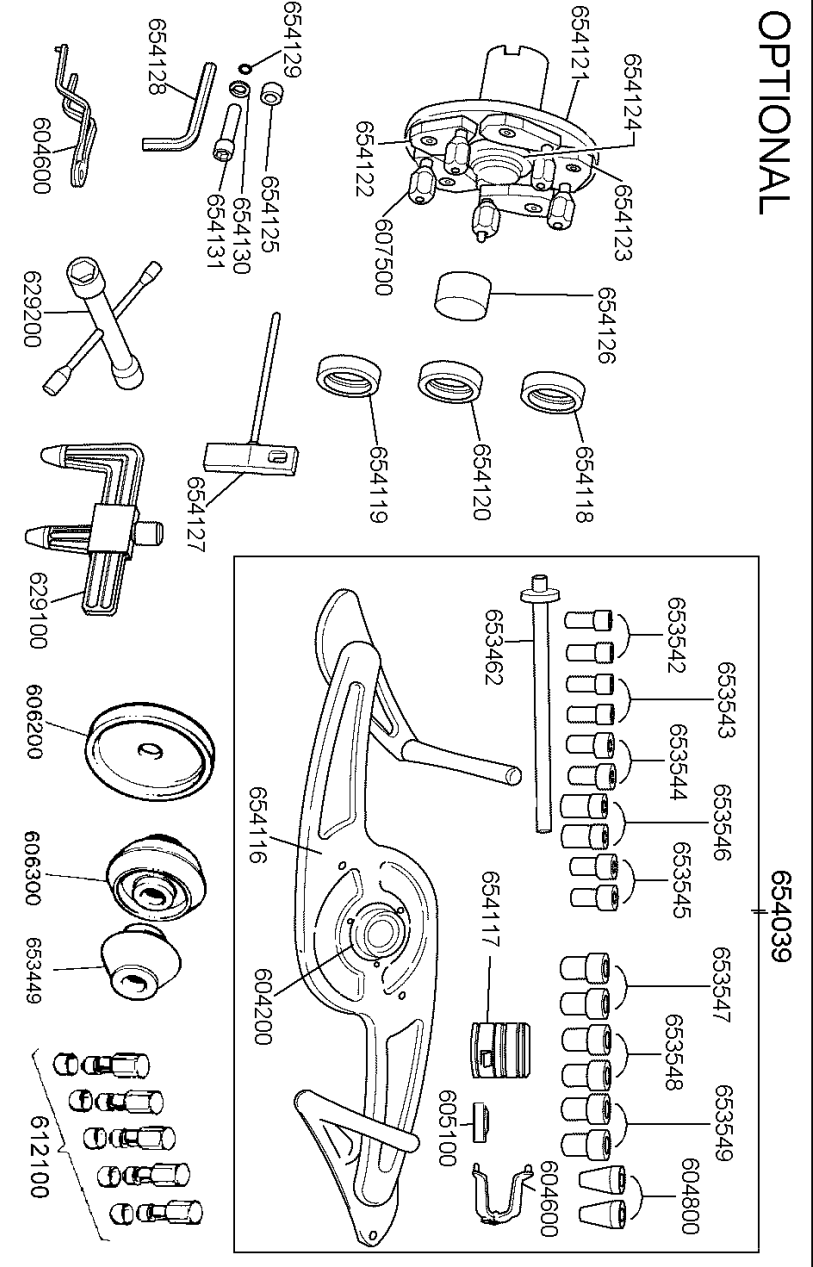

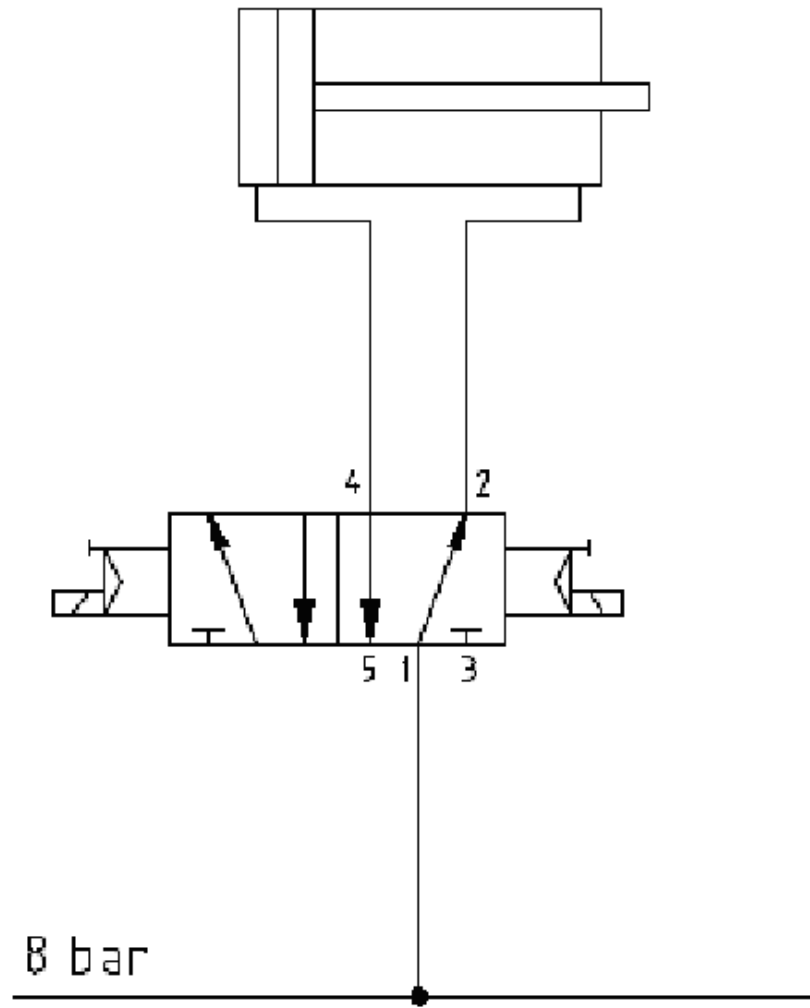

SCHEMA ELETTRICO EQUILIBRATRICE SBM V625-650 A 115/230V
SBM V625-650 BALANCING MACHINE ELECTRIC DIAGRAM AT 115/230V
DIAGRAMA DE CONEXION BALANCEADORA SBM V625-650 A 115/230V

*	mains/rete: 230V	mains/rete: 115V
T1	—	T1
L2	L2 = L1	

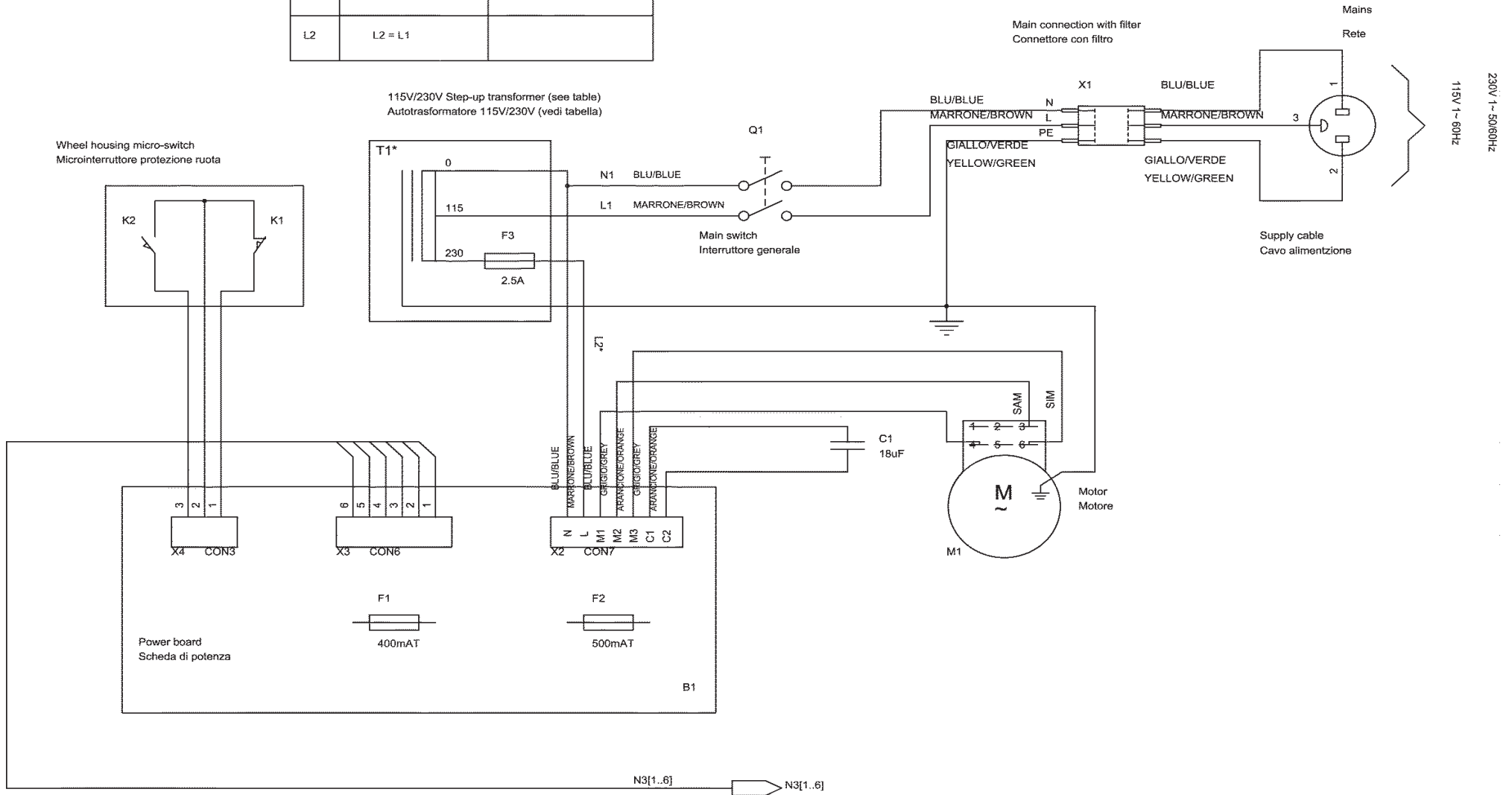

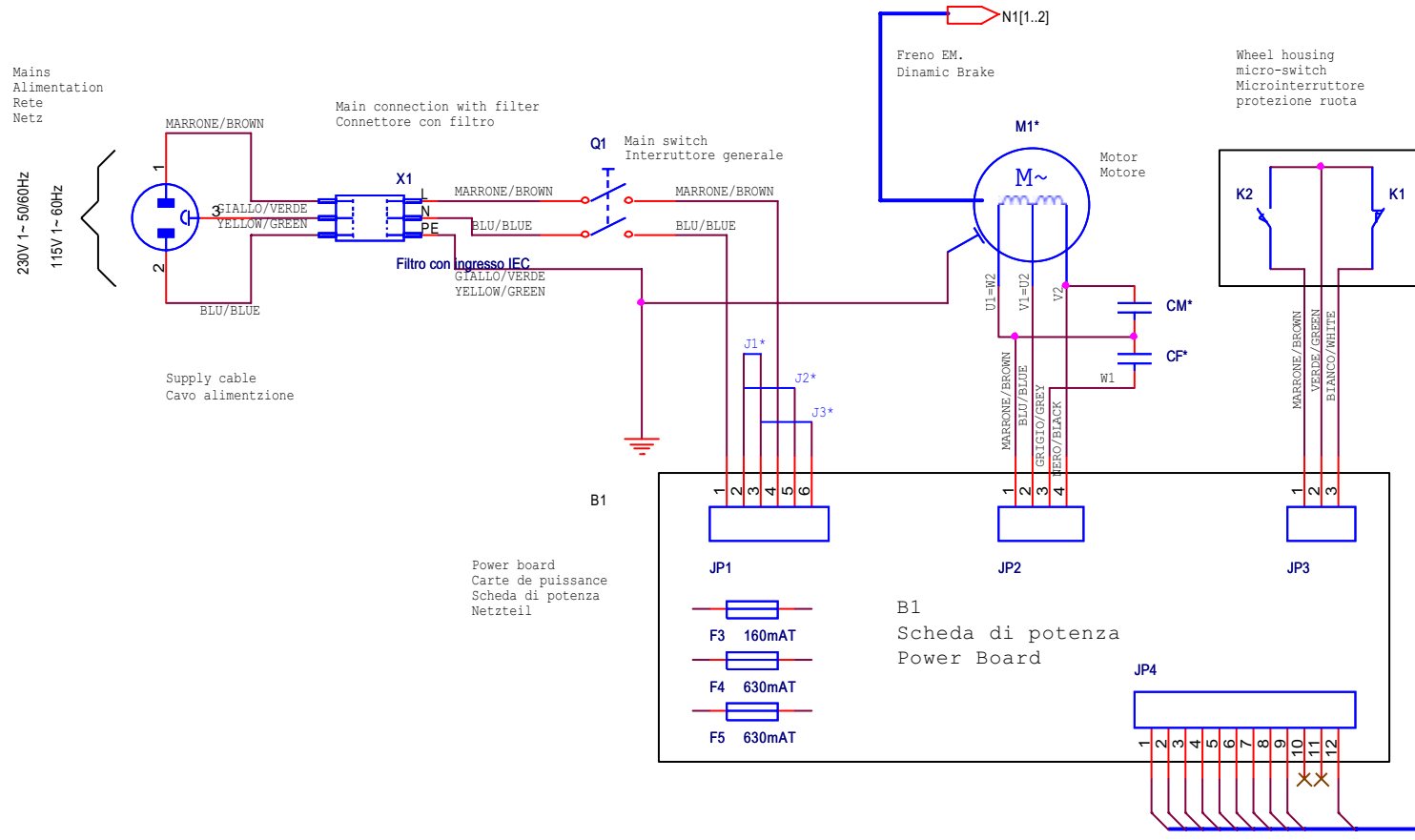

*	230V	115V
M1	230V 1~ 50/60Hz 0.37kW 950rpm	115V 1~ 50/60Hz 0.37kW 950rpm
CM	16uF 450V	75uF 450V
CF	8uF 450V	35uF 450V
J	J1	J2 , J3

Electric power board cable
Cavo elettrico scheda di potenza
N0[1..12]*

PIN	COLORE/COLOURS
1	GRIGIO/GREY
2	VIOLA/PURPLE
3	BIANCO/WHITE
4	MARRONE/BROWN
5	GIALLO/YELLOW
6	NERO/BLACK
7	BLU/BLUE
8	ROSSO/RED
9	VERDE/GREEN
12	ROSA/PINK

Electric power board cable 10x0.5
Cavo elettrico scheda di potenza 10x0.5

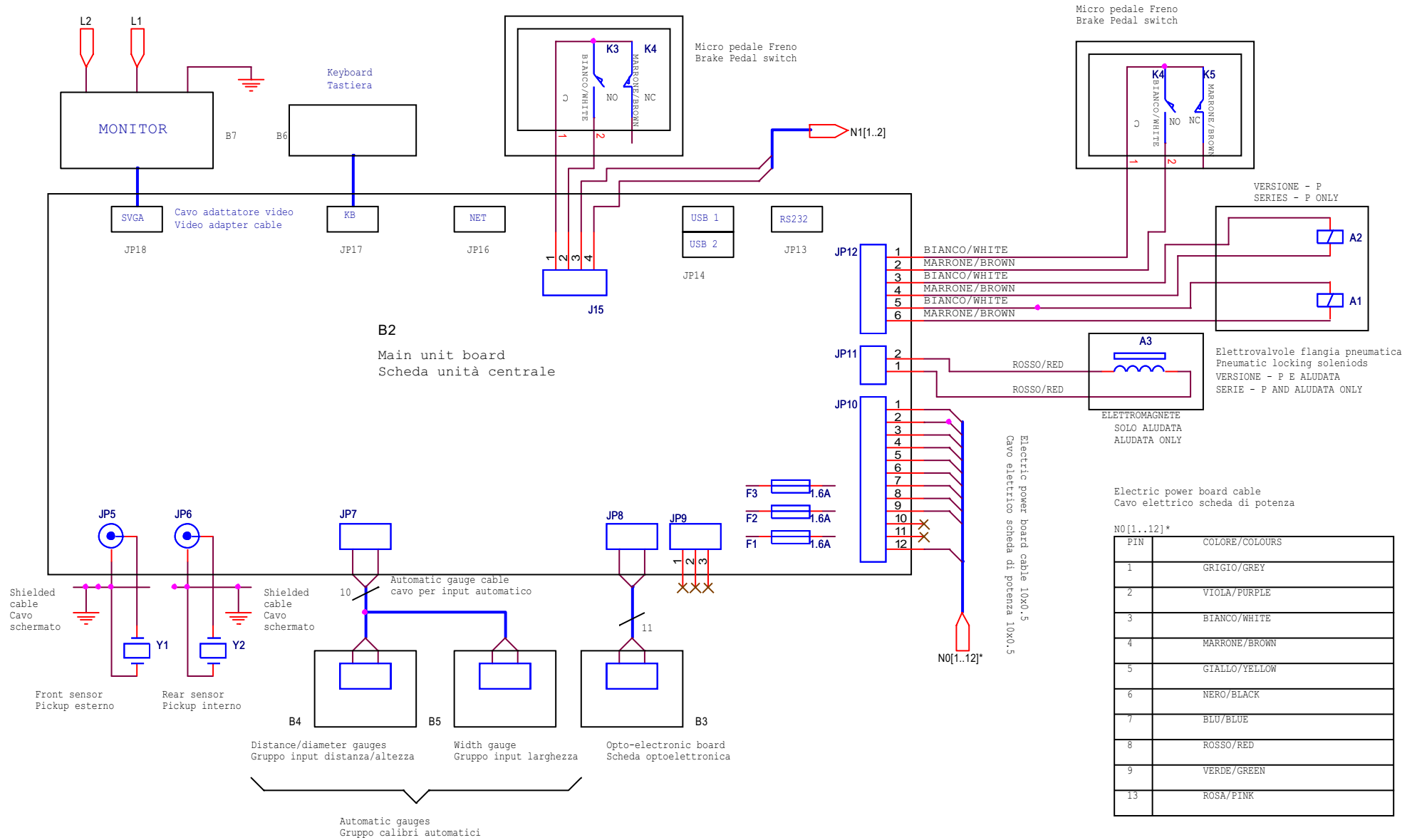

N0[1..12]*

PIN	COLORE/COLOURS
1	GRIGIO/GREY
2	VIOLA/PURPLE
3	BIANCO/WHITE
4	MARRONE/BROWN
5	GIALLO/YELLOW
6	NERO/BLACK
7	BLU/BLUE
8	ROSSO/RED
9	VERDE/GREEN
13	ROSA/PINK